

Mechanical Dimensions

表号: TE0115A

REV.	DESCRIPTION	DATE	DWN	AP'PD
0		10.12.30	Ye	Liu
1.0	Correct Appearance	15.7.10	Chen	Hsu
1.1	Correct Characteristic	16.6.13	Huang	Hsu
1.2	Correct Appearance	17.8.2	Zhou	Hsu
1.3	Correct Appearance	19.6.15	Zhou	Liu

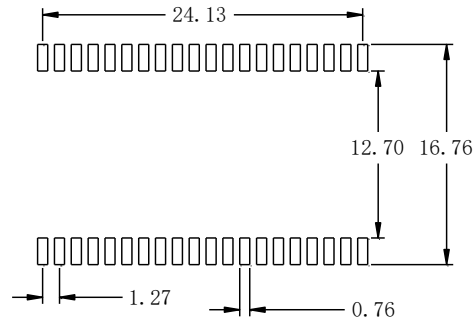
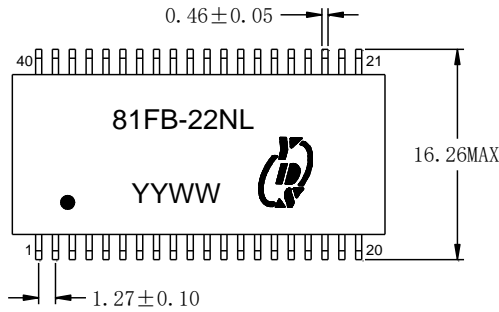

SUGGESTED PAD LAYOUT

YY:Year WW:Week

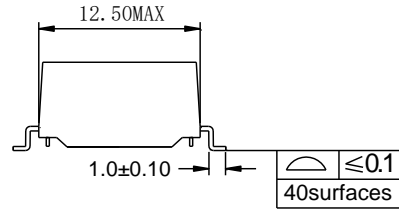
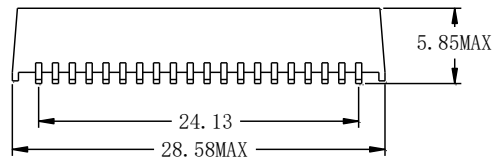

UNIT:mm Unless otherwise specified,all tolerances are ±0.25

三、 ELECTRICAL SPECIFICATIONS@25°C:

1. Turn Ratio(±3%): 1CT:1CT
2. Inductance(100KHz/0.1V@8mA): 350uH MIN
3. Insertion Loss(dB TYP): -0.5dB (0.1-100MHz)
4. Return Loss (dB MIN): -18dB(2-30MHz), -14.4dB(40MHz),
-13.1dB(50MHz), -12dB (60-80MHz)
5. HI-POT: 1500Vrms/0.5mA/60Sec or 1650Vrms/0.5mA/2Sec
6. Operating Temperature:-40°C TO +85°C
7. RoHS compliance:YES

二、 Schematics

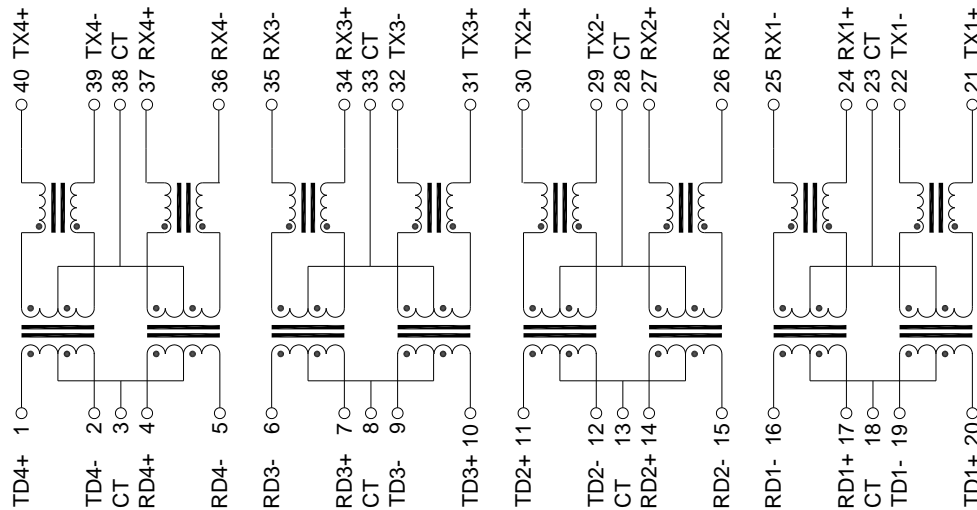

 元册科技股份有限公司 YUAN DEAN SCIENTIFIC CO., LTD.			
TITLE	10/100BASE-T MAGNETIC MODULE		
P/N	81FB-22NL	REV.	1.4
PAGE NO	1-3	DATE	2023-4-25
AP'PD	Liu zhi Jun	DWN	LIU

四、 Our RoHS parts just can withstand IR Reflow peak temperature: 245degC+/-5degC as the following profile:

REV.	DESCRIPTION	DATE	DWN	AP'PD
1.4	Correct Appearance	23.4-25	liu	liu

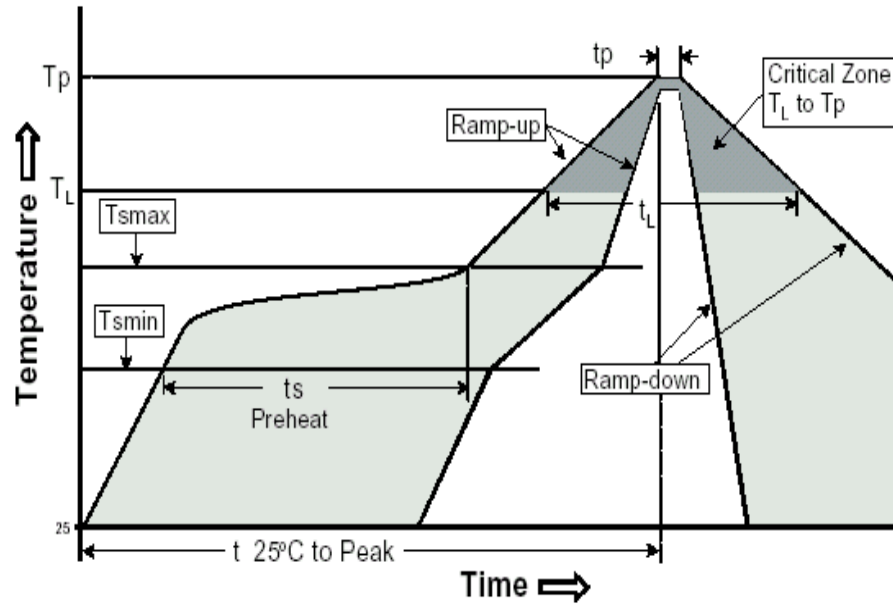

Profile Feature	Pb-Free Assembly
Average Ramp-Up Rate (Ts _{max} to Tp)	3°C /second max.
Preheat -Temperature Min (Ts _{min}) -Temperature Max (Ts _{max}) -Time (ts _{min} to ts _{max})	150°C 200°C 60-120 seconds
Time maintained above: -Temperature (T _i) -Time (t _i)	217°C 60-150 seconds
Peak/Classification Temperature (Tp)	245±5°C
Time within 5°C of actual Peak Temperature (tp)	20-40 seconds
Ramp-Down Rate	6°C/seconds max
Time 25°C to Peak Temperature	6 minutes max.



元册科技股份有限公司

YUAN DEAN SCIENTIFIC CO., LTD.

TITLE

10/100BASE-T MAGNETIC MODULE

P/N

81FB-22NL

REV.

1.4

PAGE NO

2-3

DATE

2023-4-25

AP'PD

Liu zhi Jun

DWN

LIU

五、 Packing Information:

REV.	DESCRIPTION	DATE	DWN	AP'PD

- 1.Weight----- 2.7grams/pcs
- 2.Tape & Reel----- 400pcs
- 3. outer carton unit: 2400pcs/box
- 4. outer carton unit: 6T&R/box
- 5.Weight: 11.0kg per carton

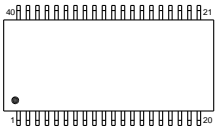

Mechanicals

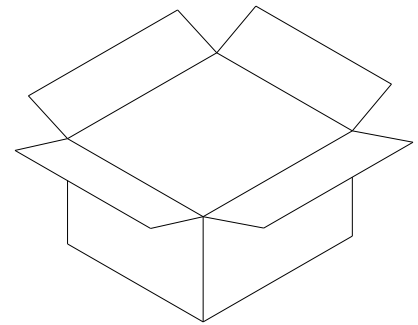
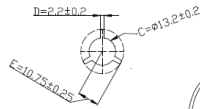
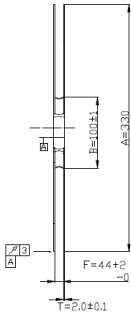
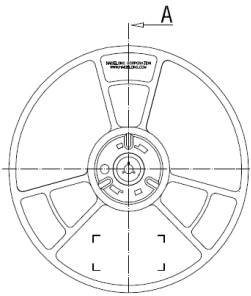
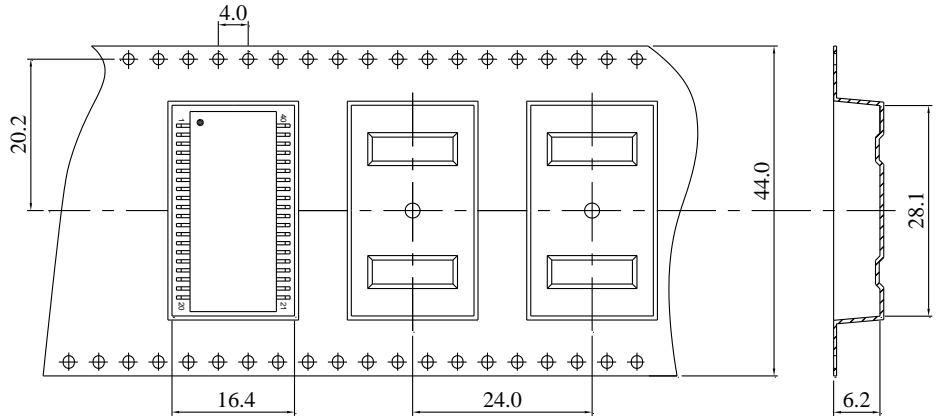

Outer carton: 365x365x350mm



元册科技股份有限公司

YUAN DEAN SCIENTIFIC CO., LTD.

TITLE	10/100BASE-T MAGNETIC MODULE		
P/N	81FB-22NL	REV.	1.4
PAGE NO	3-3	DATE	2023-4-25
AP'PD	Liu zhi Jun	DWN	LIU