

一、Mechanical Dimensions

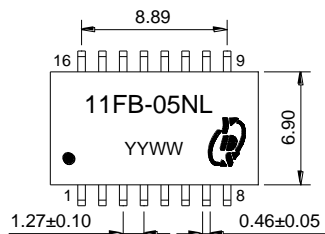

YY:Year WW:Week

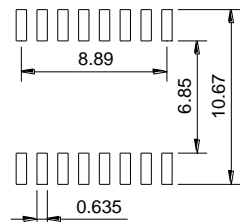

SUGGESTED PAD LAYOUT

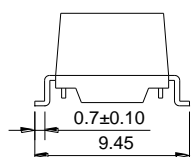
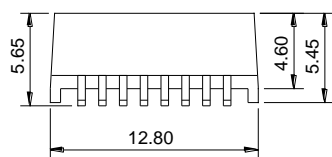

UNIT:mm Unless otherwise specified,all tolerances are ± 0.25

二、Schematics

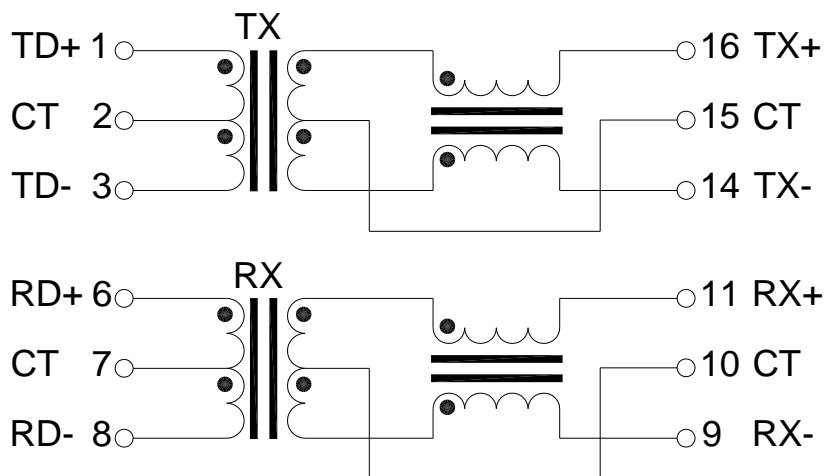

表号: TE0115A

REV.	DESCRIPTION	DATE	DWN	AP'PD
0		09.2.4	Hu	Li
1.0	Add Packing	09.7.1	Hu	Li
2.0	Correct Packing	15.9.17	Chen	Hsu
3.0	Correct Characteristic	16.3.14	Huang	Hsu
4.0	Correct Appearance	19.4.8	Zhou	Liu
4.1	Update appearance	20.2.17	Chen	Liu
4.2	Add CT and DCMR	25.10.7	Liu	Liu

三、ELECTRICAL SPECIFICATIONS@25°C:

1. Turn Ratio($\pm 2\%$):1CT:1CT
2. Inductance (OCL) (100KHz/0.1V/8mA) (P1-3, P6-8) : 350uH MIN.
3. Interwinding Capacitor (CWW) (100KHz/0.1V) (1-16, 6-11) :25pF MAX
4. Insertion Loss(dB MAX): -1.0dB(1-100MHz), -3.0dB(140MHz)
5. Return Loss(dB MIN): -16dB(5MHz), -16dB(30MHz), -13.5dB(40MHz),
-11.6dB(50MHz), -10dB(60MHz),-10dB(80MHz)
- 7.Crosstalk(dB MIN): -30dB(1-100MHz)
8. Differential To Common Mode Rejection (dB MIN): -30dB(1-100MHz)
9. HI-POT: 1500Vrms/0.5mA/60Sec or 1650Vrms/0.5mA/2Sec
10. Operating Temperature:-40°C TO +85°C
- 11.RoHS compliance:YES

RoHS
Compliant



元册科技股份有限公司

YUAN DEAN SCIENTIFIC CO., LTD.

TITLE	10/100BASE-T SINGLE PORT SURFACE MOUNT MAGNETICS		
P/N	11FB-05NL	REV.	4.2
PAGE NO	1-3	DATE	2025-10-7
AP'PD	Liu zhi Jun	DWN	Liu

四、Our RoHS parts just can withstand IR Reflow peak temperature: 245degC+/-5degC as the following profile:

REV.	DESCRIPTION	DATE	DWN	AP'PD

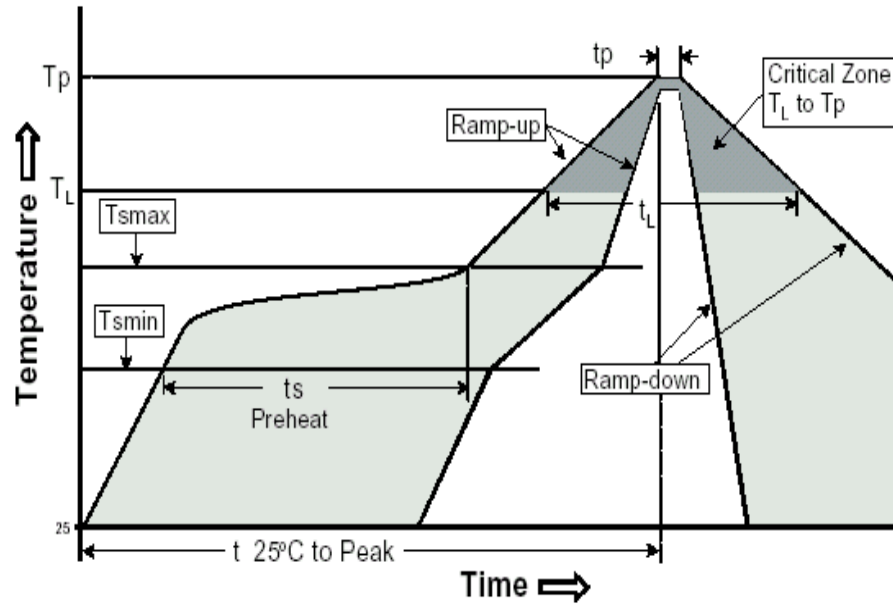

Profile Feature	Pb-Free Assembly
Average Ramp-Up Rate (T_{smax} to T_p)	3°C /second max.
Preheat	
-Temperature Min (T_{smin})	150°C
-Temperature Max (T_{smax})	200°C
-Time (t_{smin} to t_{smax})	60-120 seconds
Time maintained above:	
-Temperature (T_L)	217°C
-Time (t_L)	60-150 seconds
Peak/Classification Temperature (T_p)	245±5°C
Time within 5°C of actual Peak Temperature (t_p)	20-40 seconds
Ramp-Down Rate	6°C/seconds max
Time 25°C to Peak Temperature	6 minutes max.



元册科技股份有限公司

YUAN DEAN SCIENTIFIC CO., LTD.

TITLE

10/100BASE-T SINGLE PORT SURFACE MOUNT MAGNETICS

P/N

11FB-05NL

REV.

4.2

PAGE NO

2-3

DATE

2025-10-7

AP'PD

Liu zhi Jun

DWN

Liu

五、 Packing Information:

REV.	DESCRIPTION	DATE	DWN	AP'PD

- 1.Weight-----0.7 grams/pcs
- 2.Tape & Reel----- 700 pcs
- 3. outer carton unit: 7000pcs/box
- 4. outer carton unit: 10 T&R/box
- 5.Weight: 10.5kg per carton

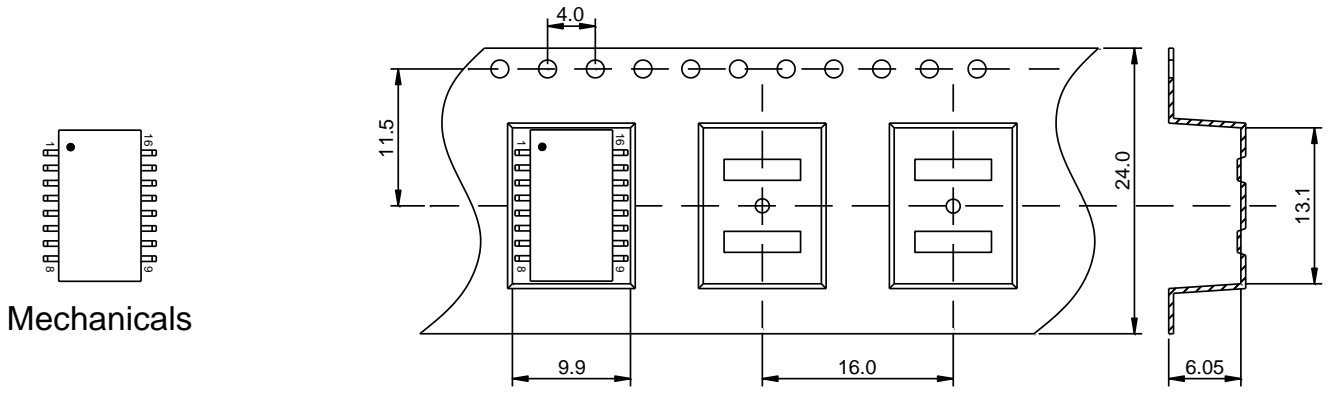

Tape & Reel

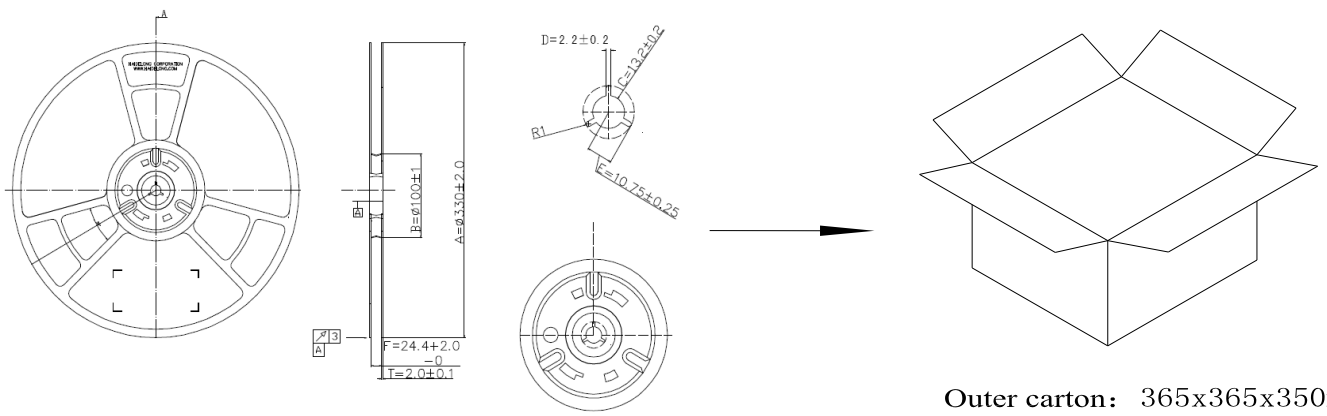

Outer carton: 365x365x350mm

<p>RoHS Compliant</p>	<p>元册科技股份有限公司 YUAN DEAN SCIENTIFIC CO., LTD.</p>			
	TITLE		10/100BASE-T SINGLE PORT SURFACE MOUNT MAGNETICS	
	P/N	11FB-05NL	REV.	4.2
	PAGE NO	3-3	DATE	2025-10-7
	AP'PD	Liu zhi Jun	DWN	Liu